

FORTÉ

36" Freestanding Dual Fuel Range

FDR366BSS

[CLICK TO VIEW
IN KITCHEN](#)

FRONT



KNOBS



BURNER



PRODUCT DIMENSIONS

Width	36 in.	91.44cm
Height	37 ⁸ / ₁₆ in.	95.25cm
Depth	28 ¹² / ₁₆ in.	73cm
Depth w/ Door Open 90°	45 ¹² / ₁₆ in.	122.25cm
Oven Usable Width	29 in.	73.66cm
Oven Usable Height	14 in.	35.56cm
Oven Usable Depth	17 in.	43.18cm
Oven Actual Width	30 ¹⁰ / ₁₆ in.	63.18cm
Oven Actual Height	14 in.	35.56cm
Oven Actual Depth	17 in.	43.18cm
Height Between Rack Mounts	3 ¹² / ₁₆ in.	9.53cm
Max. Height Between Racks	8 ² / ₁₆ in.	20.64cm
Oven Capacity*	4.5 Cu. Ft.	127.4L

*NOTE: Capacity is prior to broiler, oven rack(s), and convection fan.
Actual space excludes rack placements and accessories.

ADDITIONAL SPECS

No. of Burners	6
No. of Interior Lights	2
Rated Voltage	240V-60Hz
Amperage	25 Amps
Warranty Terms	2 Year
Certification	ETL
Conversion Kit	Yes

FEATURES:



20K DUAL BRASS BURNER

Provides powerful flexibility, going from a simmer to boiling hot in an instant.



EASY GLIDE RACKS

Easy glide racks deliver quality and convenience with consistent ease.



EDGE-TO-EDGE GRATES

Edge to edge grates provide a truly level cooktop, perfect for easily transferring pots and pans.



CONVERTIBLE POWER

Diversify your kitchen with a range which supports natural gas and liquid propane conversion.

INSTALLATION GUIDE

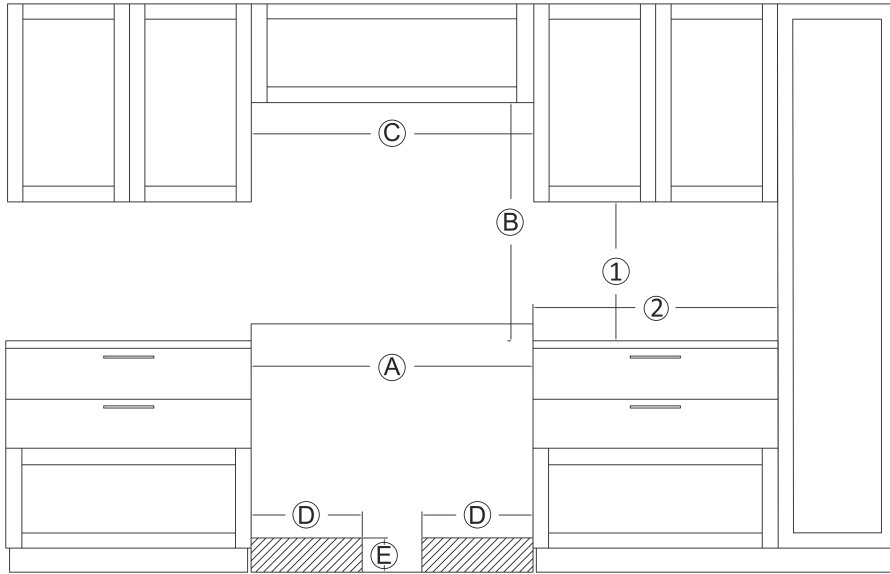

POSITION	DIMENSIONS	DESCRIPTIONS
1	18"/45.7cm	Minimum distance to bottom edge of top cabinet
2	12"/30.48cm	Minimum distance from cooktop surface
A	36"/91.44cm	Width of cabinet opening
B	26"-32" 66.04-81.28cm	Min. and max. height between cooktop and hood
C	36"/91.44cm	Minimum width of the hood area
D	Approx. 10 ¹³ / ₁₆ "/27.4cm	Maximum gas/elec. connection width from right and left
E	Approx. 4 ⁸ / ₁₆ "/11.5cm	Maximum gas/elec. connection height

DIMENSIONS:

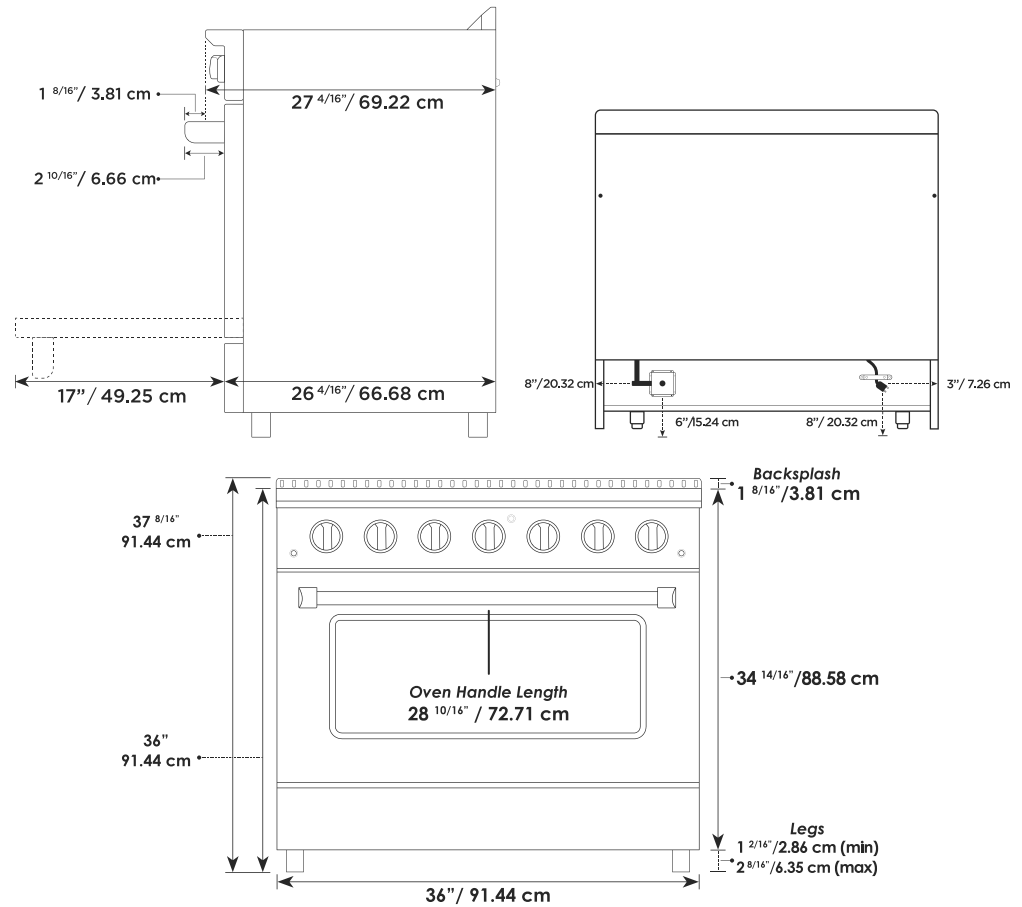

BURNER MAP:

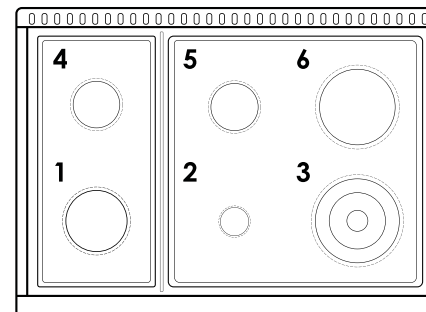

- BURNER 1**
LARGE (15,000 BTU)
- BURNER 2**
SMALL (6,000 BTU)
- BURNER 3**
DUAL (20,000 BTU)
- BURNER 4**
STANDARD (9,000 BTU)
- BURNER 5**
STANDARD (9,000 BTU)
- BURNER 6**
LARGE (12,000 BTU)